

# **SIGNODE** **LBX-2300**™ **STAINLESS** **STEEL**

*Semiautomatic stainless steel plastic strapping machine*

**Reliable  
packaging  
under harsh  
conditions**

*for the*  
**Meat, Poultry  
and Seafood**  
*industries*



*Up to 70 straps per minute!*

# SIGNODE LBX-2300™ STAINLESS STEEL

**Semiautomatic stainless steel plastic strapping machine**

The LBX-2300™ semiautomatic strapping machine is the simplest, most reliable general-duty strapping machine on the market today. With 40% fewer parts and more timesaving features, the LBX-2300 machine simplifies operation and maintenance to save you time and money.

## Unmatched simplicity

The LBX-2300's simple yet durable design eliminates the use of drive belts and clutches to simplify operation and maintenance. It comes standard with a number of features, making it easier to operate than other strapping machines.

- Jam-resistant technology
- Bi-directional coil loading
- Out-of-strap feature
- Fully accessible strap path
- Toolless hot knife removal
- Automatic cut-off and refeed option

## Reliable packaging

The LBX-2300 is designed for reliable packaging under harsh conditions. Built with stainless steel components, it is ideal for packaging applications where corrosion resistance is necessary.

### Stainless steel components

- Frame
- Rear panels
- Dispenser door
- Legs
- Slack box
- Electrical door
- Splash guard

### Save on strapping costs with the LB Series plastic strapping

The LBX-2300 utilizes Signode's newest Contrax® polypropylene strapping. LB Series strapping has the same durable properties as regular Contrax with more strap per coil.

- LB 112 5 mm Contrax coils – 30,000 feet per coil
- LB 212 6 mm Contrax coils – 24,000 feet per coil

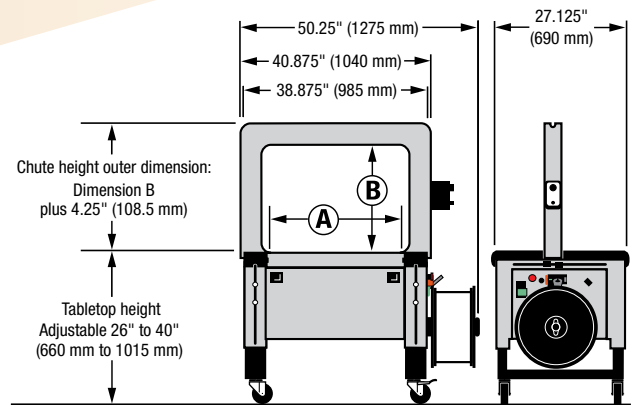

**LBX-2300 Chute inner dimensions**

	in.	mm
A*	28	710
B	20	510

\*Inner dimension A is maximum package size.

## LBX-2300 Specifications

**Cycle rate:** Up to 70 straps per minute. Actual production will vary depending on package size, chute size and operator dexterity.

**Maximum package weight:** 100 lbs

**Strapping:** 5 mm or 6 mm Contrax polypropylene strapping

**Electrical requirements:** 120 volt, 60Hz, FLA 7 amp;  
3 phase voltage optional

**Shipping weight:** 600 lbs

## LBX-2300 Options

- Single or dual compression  
Single: Up to 120 lbs at 90 lbs psi  
Dual: Up to 240 lbs at 90 lbs psi
- Indicator light alerts operator to low strap/out-of-strap conditions and machine malfunction
- EZ height adjustable leg kit — 26" to 40" (660 mm to 1015 mm)
- Automatic cut-off and refeed

**The LBX-2300 is also available in an automatic model, the LBX-2330.**

**SIGNODE®**

3610 West Lake Avenue  
Glenview, Illinois 60026  
1-800-323-2464  
www.signode.com